

"Big Red" TEC-950L

Loaded Container Handler Standard Specifications

Rated Capacity 67,200-lbs. (30,482 kg) / 4-high Stacking

Rated Capacity 75,000-lbs. (34,020 kg) / 3-high Stacking

Rated Capacity 80,000-lbs. (36,288 kg) / 2-high Stacking

102.75-in. (2,610 mm) Center Of Load

225-in. (5,715 mm) Wheelbase

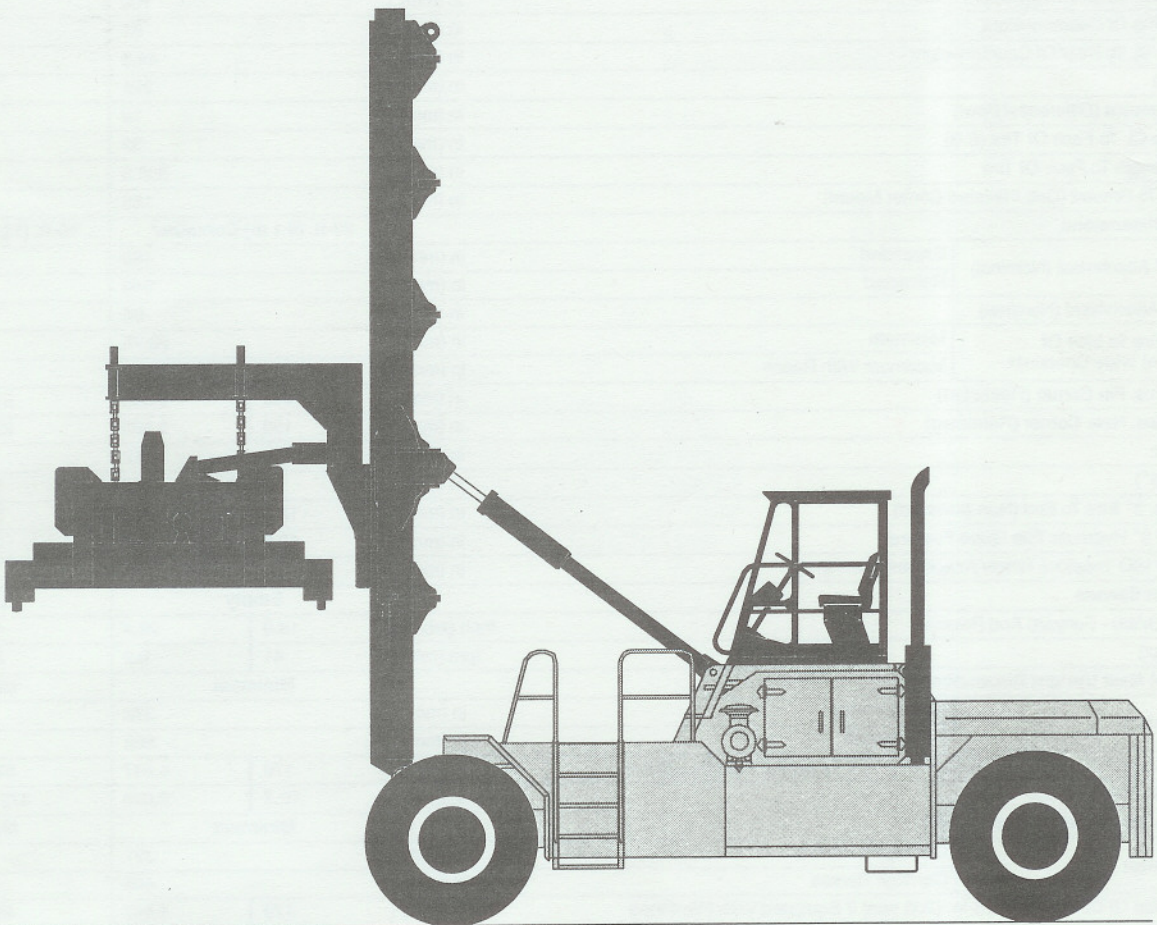

"Big Red" TEC-950L Loaded Container Handler

Manufacturer's Name		TAYLOR		TAYLOR		
		TEC-950L Loaded Container Handler				
Manufacturer's Designation		English	Metric	English	Metric	
		32.5-ft. (9.9 m) Mast		Optional 24-ft. (7.3 m) Mast		
Rated 2-high Stacking Capacity At 102.75-in. (2,610 mm) Center Of Load (Ctr. Of Load To Ctr. Of Axle)		lb (kg)	80,000	36,288	80,000	36,288
Rated 3-high Stacking Capacity At 102.75-in. (2,610 mm) Center Of Load (Ctr. Of Load To Ctr. Of Axle)		lb (kg)	75,000	34,020	75,000	34,020
Rated 4-high Stacking Capacity At 102.75-in. (2,610 mm) Center Of Load (Ctr. Of Load To Ctr. Of Axle)		lb (kg)	67,200	30,482	-	-
Load Moment With Attachment And 80,000-lbs. (36,288 kg) Rating		in-lb (m-kg)	8,220,000	94,706	8,220,000	94,706
Tractive Effort At Stall		lb (kN)	45,462	202	45,462	202
Vehicle Weight - Empty	Drive Axle	lb (kg)	103,000	46,721	98,100	44,498
	Steer Axle	lb (kg)	52,200	23,678	52,200	23,678
Vehicle Weight - Loaded	Drive Axle	lb (kg)	219,533	99,580	214,633	97,358
	Steer Axle	lb (kg)	15,677	7,111	15,667	7,107
Gradeability At 0.9 Coef.	Empty	%			26.5	
	Loaded	%			16.7	
Grade Clearance	Center Of Truck	%			46	
	Rear Overhang	%			70	
Tires		18.00 R25 - 32 PR Radial				
Machine Dimensions						
1 - Width Across Counterweight		in (mm)	120		3,048	
2 - Tread Width, Drive Axle		in (mm)	148.5		3,772	
3 - Width Over Drive Tires		in (mm)	192		4,877	
4 - Outside Turn Radius (Tailswing)		in (mm)	298.5		7,582	
5 - Inside Turn Radius		in (mm)	0		0	
6 - Height To Top Of Overhead Guard / Cab		in (mm)	162		4,115	
7 - Height To Top Of Counterweight		in (mm)	81		2,057	
8 - Steer Axle CL To Rear Of Counterweight		in (mm)	46.5		1,181	
9 - Wheelbase		in (mm)	225		5,715	
10 - Underclearance (Differential Bowl)		in (mm)	15		381	
11 - Drive Axle CL To Face Of Tire (E-3)		in (mm)	32		813	
12 - Overall Length To Face Of Tire		in (mm)	303.5		7,709	
Operator Eye To Ground (Cab Elevated Center Mount)		in (mm)	155		3,937	
Attachment Dimensions			20-ft. (6.1 m) Container		40-ft. (12.2 m) Container	
13 - Length Of Attachment (Nominal)	Expanded	in (mm)	480		12,192	
	Retracted	in (mm)	240		6,096	
14 - Width Of Attachment (Nominal)		in (mm)	96		2,438	
15 - Face Of Tire To Side Of 8-ft. (2.4 m) Wide Container	Minimum	in (mm)	22.75		578	
	Maximum With Reach	in (mm)	29.25		743	
16 - Turn Radius, Far Corner (Retracted)		in (mm)	263	6,680	368	9,347
17 - Turn Radius, Near Corner (Retracted)		in (mm)	153	3,886	206	5,232
18 - Sideshift ±		in (mm)	12		305	
19 - Slewing (5°)		in (mm)	25	635	50	1,270
20 - Pile Slope, 3° End To End (Non-powered)		in (mm)	12.5	318	25	635
20A - Optional 3° Hydraulic Pile Slope Feature		in (mm)	12.5	318	25	635
21 - Length Of ISO Twistlock Below Attachment (Nominal)		in (mm)	4		102	
Travel And Lift Speeds			Empty		Loaded	
Travel Speed (Max) - Forward And Reverse		mph (km/h)	13.9	22.4	12	19.3
Lift Speed (Max)		fpm (m/s)	41	0.2	39	0.2
32.5-ft. (9.9 m) Mast Upright Dimensions			Minimum		Maximum	
A - Height Of Mast	Fully Lowered	in (mm)	372		9,449	
	Fully Raised	in (mm)	568		14,427	
B - Height To Top Of Carriage, Add 8-in. (203 mm) If Equipped With Pile Slope		in (mm)	179	4,547	569	14,453
C - Height To Tip Of Twistlock		in (mm)	82.5	2,096	472.5	12,002
Optional 24-ft. Mast Upright Dimensions			Minimum		Maximum	
A - Height Of Mast	Carriage Lowered	in (mm)	321		8,153	
	Carriage Raised	in (mm)	465		11,811	
B - Height To Top Of Carriage, Add 8-in. (203 mm) If Equipped With Pile Slope		in (mm)	179	4,547	467	11,862
C - Height To Tip Of Twistlock		in (mm)	82.5	2,096	370.5	9,411

NOTE: Performance specifications are for machines equipped as described on the back page of this specification sheet. Performance specifications are affected by the condition of the vehicle, its components, and the nature and condition of the operating area. If these specifications are critical, the proposed application should be discussed with your Taylor sales representative.

"Big Red" TEC-950L Loaded Container Handler

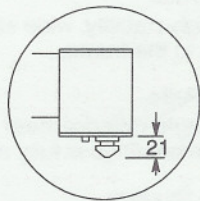
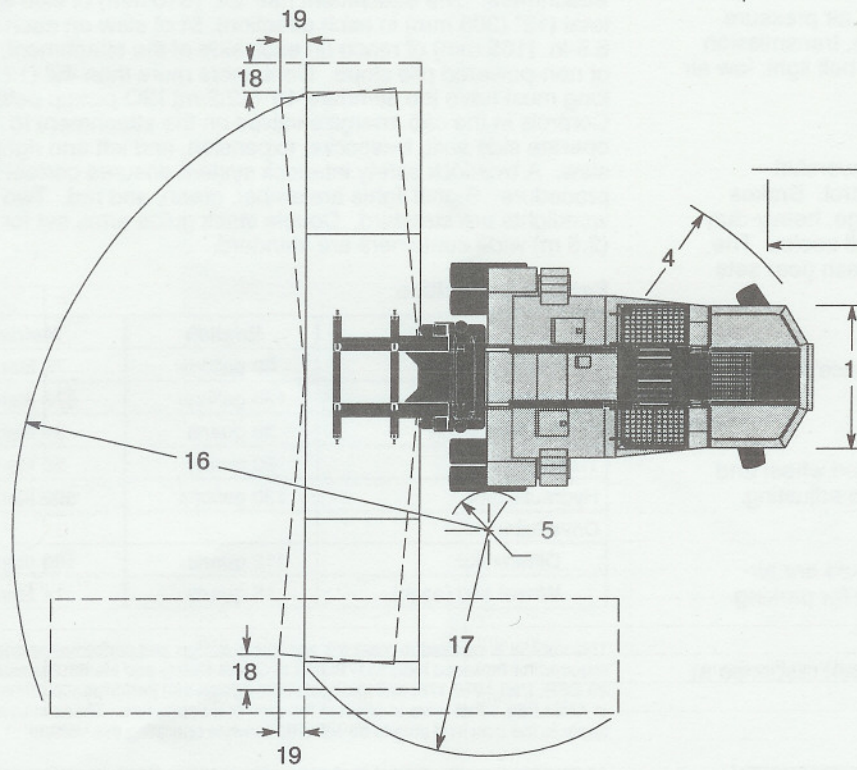
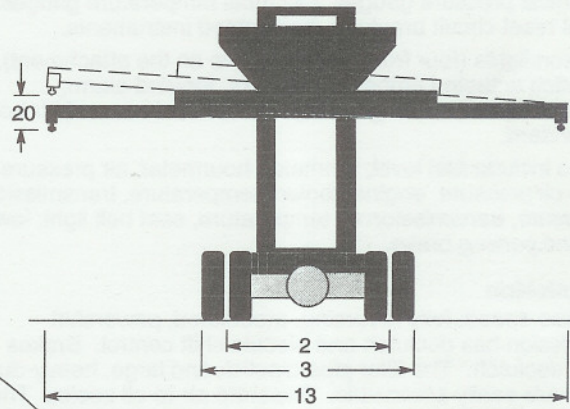
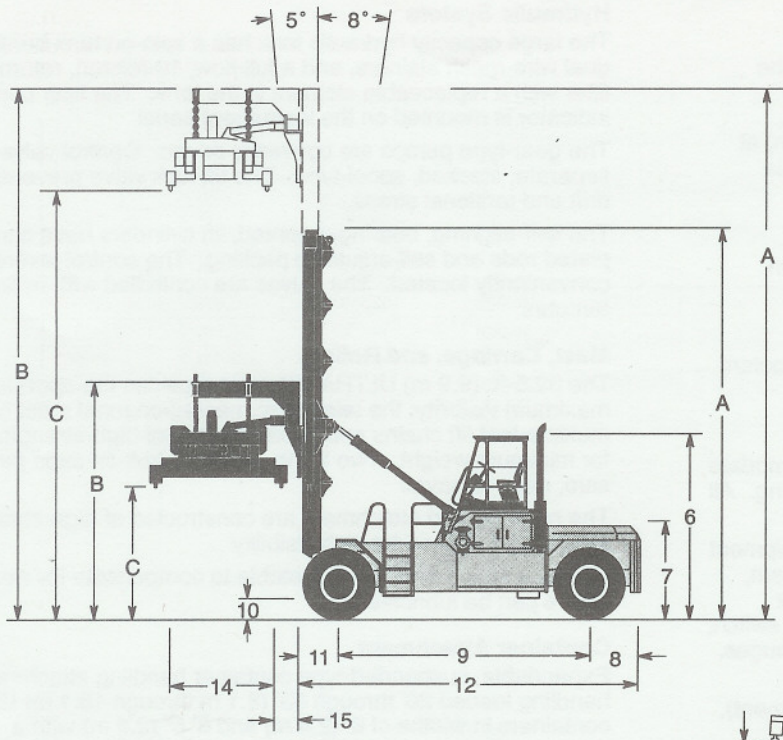

Twistlock Detail

"Big Red" TEC-950L Loaded Container Handler

Engine

Cummins M11-C260 turbo-charged diesel engine has 260 (194 kW) gross brake horsepower at 2100 rpm. The 4-cycle in-line 6 cylinder engine has 661 cu-in. (11L) displacement. The bore is 4.92-in. (108 mm) x 5.79-in. (146 mm) stroke. Peak torque is 845 ft-lbs. (1,150 N-m) at 1300 rpm. (SAE J1349). A fuel filter / water separator is standard.

Air Cleaner

The Donaldson 2-stage, heavy-duty, dry air cleaner with restriction indicator is easily serviced.

Cooling System

The deaeration tank, with a sight gauge for checking coolant level, provides optimum engine cooling.

Electrical, Instrumentation, and Accessories

The one-piece instrument panel is pre-wired to accommodate heavy-duty accessories and flips down for easy servicing. All wiring is color coded.

The unit has a 12-volt electrical system. Standard equipment includes a full-kill engine / transmission protection system, key-type anti-restart ignition system, two 220 amp-hour batteries, 100-amp alternator, main battery disconnect switch, mechanical pressure gauges, electrical temperature gauges, thermal reset circuit breakers, and lighted instruments.

Eight worklights (four front, two rear, two on the attachment), key-switch actuated amber strobe light, forward alarm, reverse-actuated warning alarm, rear-view mirror, and air horn are standard.

Gauges include fuel level, ammeter, hourmeter, air pressure, engine oil pressure, engine coolant temperature, transmission oil pressure, transmission oil temperature, seat belt light, low air light, and parking brake.

Transmission

The three-speed, fully reversing, modulated, powershift transmission has declutch and electric shift control. Brakes behind declutch. The filler pipe dipstick and large, heavy-duty oil filter are easily accessible. Separate air-to-oil cooler. The integrally built torque converter has constant-mesh gear sets actuated by hydraulic clutch packs.

Drive Axle

The high-stability, wide stance, planetary drive axle's housing is bolted to the frame.

Steer Axle

The single-cylinder steer axle design with tapered wheel and kingpin bearings is fully sealed and never needs adjusting.

Brake System

The internal force-cooled, wet disc, service brakes are air-actuated. The drive-line brake is spring applied for parking.

Power Steering

The hydrostatic steering system provides constant response at all engine speeds.

Chassis

The all-welded frame has an integral, sloped counterweight. Hinged doors provide easy access to all service points. The elevated, center mount operator and overhead guard with 2-door cab tilts forward to aid in engine removal. The cab is equipped with a 25,000 BTU heater, front windshield wiper, and defroster fan. The adjustable air suspension seat has adjustable-angle armrests and an operator seat belt.

Hydraulic System

The large capacity hydraulic tank has a spin-on tank breather, dual wire-mesh strainers, and a full-flow, 10-micron, return-line filter with a replaceable element in the tank. The filter condition indicator is mounted on the instrument panel.

The gear-type pumps are converter driven. Control valves are separate, stacked, spool-type. The tilt-lock valve prevents mast drift and torsional stress.

The self-aligning, bearing-mounted, lift cylinders have chrome plated rods and self-adjusting packing. The control levers are conveniently located. The valves are controlled with hydraulic remotes.

Mast, Carriage, and Rollers

The 32.5-ft. (9.9 m) ULTRA-VU mast provides the operator with maximum visibility; the telescopic, nested-channel mast has two multiple-leaf lift chains and is constructed of high-strength steel for minimum weight. Two lifting eyes and bolt-on caps permit safe, easy removal.

The carriage and attachment are constructed of high-strength steel and designed for high visibility.

Carriage side rollers are adjustable to compensate for wear. All rollers can be lubricated.

Container Attachment

Expandable, suspended-type container handling attachment for handling loaded 20' through 53' (6.1 m through 16.1 m) ISO containers in widths of 8' (2.4 m) and 8' 6" (2.6 m) with a maximum weight of 80,000-lbs. Includes all hydraulics, electrical circuitry, and an electrical signal system for operation of the attachment. The attachment has 24" (610 mm) of side shift total (12" (305 mm) in each direction), 5° of slew on each end, 6.5-in. (165 mm) of reach on each side of the attachment, and 3° of non-powered pile slope. Containers more than 40' (12.2 m) long must have the standard 40' (12.2 m) ISO pickup points. Controls in the cab energize valves on the attachment to operate side shift, twistlocks, expansion, and left and right hand slew. A twistlock safety interlock system ensures correct locking procedure. Signal lights are amber, green, and red. Two worklights are standard. Double stack guide arms set for 8'6" (2.6 m) wide containers are standard.

Service Capacities

	English	Metric
Cooling system	20 gallons	76 liters
Fuel tank	125 gallons	473 liters
Engine lubrication	36 quarts	34 liters
Transmission	60 quarts	56 liters
Hydraulic tank	130 gallons	492 liters
Drive axle:		
Differential	112 quarts	106 liters
Wheel end (each)	15 quarts	14 liters

This vehicle is certified to meet the applicable design and performance criteria required for Powered Industrial Trucks in OSHA Safety and Health Standards, Title 29 CFR, Part 1910.178, and the applicable design and performance requirements in ANSI B56.1 that were in effect at the time of manufacture. These standards also apply to the user and should be adhered to while operating this vehicle.

All specifications are subject to change without notice. Some operating data may be affected by the condition of the operating area. If these specifications are critical, contact the factory.

K1 (8/97)
Printed in U.S.A.

Taylor Machine Works, Inc.

650 North Church Avenue
Louisville, Mississippi 39339-2017
Phone (601) 773-3421 Fax (601) 773-9146